

Passenger Briefing and Cabin Features Guide

*Providing On-Demand Executive Air Charter
and Express Air Cargo*

(903) 784-7133 www.airdirect.us charter@airdirect.us

Table of Contents

Pre-Trip Information & Passenger ID Requirements.....	3
TSA Prohibited Items	4
ForeFlight Passenger Access.....	5
Iridium GO! In-Flight Connectivity.....	5
Cabin Layout	6
Cabin Information Display	7
Passenger Comfort: Temperature Control	7
Iridium GO! In-Flight Connectivity Guide	8
Iridium GO! Quick Calling Guide.....	10
Cabin Switch Panels.....	13
Furniture Location & Operation	16
Seat Adjustment.....	16
Emergency Equipment	21
Emergency Exits.....	22
Fire Extinguishers	23
Life Vests.....	24
Overhead Oxygen Masks.....	25
Seat Belts	25

Privacy Notice

The Transportation Security Administration (TSA) requires you to provide your full name, date of birth, and gender for the purpose of watch list screening, under the authority of 49 U.S.C. section 114, the Intelligence Reform and Terrorism Prevention Act of 2004 and 49 C.F.R parts 1540 and 1560. You may also provide your Redress Number, if available.

Failure to provide your full name, date of birth, and gender may result in denial of transport or denial of authority to enter the boarding area.

TSA may share information you provide with law enforcement or intelligence agencies or others under its published system of records notice.

For more on TSA privacy policies, or to review the system of records notice and the privacy impact assessment, please see the TSA Web site at www.tsa.gov.

Pre-Trip Information & Passenger ID Requirements



Before your trip, there are a few brief things that all passengers need to be informed of. They're contained in the first section of this booklet.

The rest of this booklet contains information on the various passenger conveniences and cabin features found aboard our Citation 560XL aircraft, and we invite you to learn as much as you want about the aircraft before your trip.

Important information:

- All Passengers who will be traveling with us are required by Federal Regulations to provide full name, date of birth and gender. We prefer to have these ahead of time so that there is no delay in boarding.

*Adding an additional passenger on the day of the trip?
No problem, just let us know and we will accommodate.*

- Passengers who are 18 years of age or older will be asked for their ID so that the flight crew may verify their identity prior to boarding. Any combination of the following will suffice:
 - **1 Unexpired Government-issued photo ID**
(Driver's License, Passport, etc.)
 - **1 Government-issued ID and one other form of ID**
(Social Security Card and School ID, or Work ID, for example)
Don't have ID? Let us know ahead of time so that we can help prevent delays in boarding.

Federal Regulations require the flight crew to ask for ID each time a passenger boards the aircraft.

Compliance is monitored and strictly enforced by the TSA, so please be prepared to show ID on each leg of the trip.

TSA Prohibited Items

Federal Regulations prohibit passengers from bringing **certain items** in their carry-on luggage, some items are not allowed to be carried in the external baggage compartment, and some **hazardous items are prohibited** from being carried aboard the aircraft at all.

A full list of these items can be found at: www.TSA.gov
Here is a brief summary:

- **Weapons** are not allowed to be carried inside the cabin of the aircraft. This includes firearms, knives, pepper spray, stun guns and martial arts items.
- **Firearms** may be carried in the external baggage compartment provided they are declared and verified unloaded by the crew.
- **Ammunition** may be carried in the external baggage, in an approved container.
- **Certain tools** and sporting goods are not allowed in the cabin.
- **Explosives and flammable items** are not allowed aboard the aircraft. Cigarette lighters or matches are only allowed in carry-on baggage.
- **Dangerous chemicals**, spillable batteries, and compressed gas cylinders are prohibited aboard the aircraft. There are certain exceptions for medical oxygen that may be discussed prior to your flight.
- **Hazardous Materials** or HAZMAT items are prohibited.
- **Lithium batteries** are only allowed in the cabin. Due to the risk of fire, they are prohibited from being carried in the external baggage compartment. This includes devices which contain lithium batteries.
- **E-Cigarettes** or Vaping devices are prohibited from being carried in the external baggage compartment, and are only allowed in carry-on luggage. Also, due to the dangers involved with lithium batteries, charging of E-Cigarettes or E-Cigarette batteries is prohibited in the cabin.
- **No Smoking** of any kind is allowed aboard the aircraft, including E-Cigarettes.

Have questions?

Contact us and we will help in any way we can.

ForeFlight Passenger Access

Inflight Insight for Passengers

[ForeFlight Passenger](#) is the app that answers the question “Are we there yet?”, by keeping passengers fully informed about their flight. Passenger provides helpful flight information like time to destination, expected arrival time, altitude, groundspeed, and course. Any time your pilots make changes to the route, Passenger will automatically update the route shown to reflect those changes.

Download and Go

Passenger is free to download from the App Store. Just open the app and you're all set to start following along. Tell your friends, family, and anyone else who rides along to download Passenger before boarding!

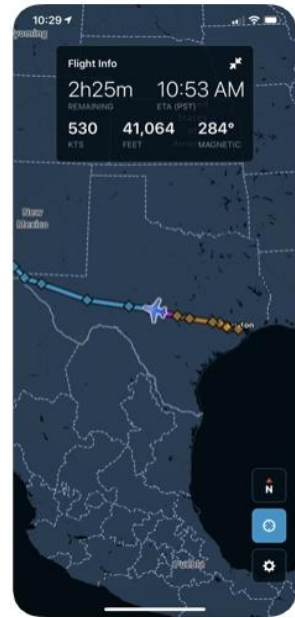

Need help? Check out the [ForeFlight Passenger Guide](#).

Iridium GO! In-Flight Connectivity



Smartphone connectivity for voice calling and SMS texting is provided by the Iridium network.



Before boarding, download the free Iridium GO! app on your smartphone. Once aboard, connect to the Air Direct WiFi network. Once your device is connected, open the Iridium GO! app, and login. The username is 'guest', and the password is '1234'.

Once you're connected, you may use the Iridium GO! app to place or receive voice calls, and send and receive SMS text messages.

For more information on using the Iridium GO! app, see the [Iridium Quickstart Guide](#).

For voice calling and SMS text instructions, please see pages 7-9 of this guide.

Cabin Layout

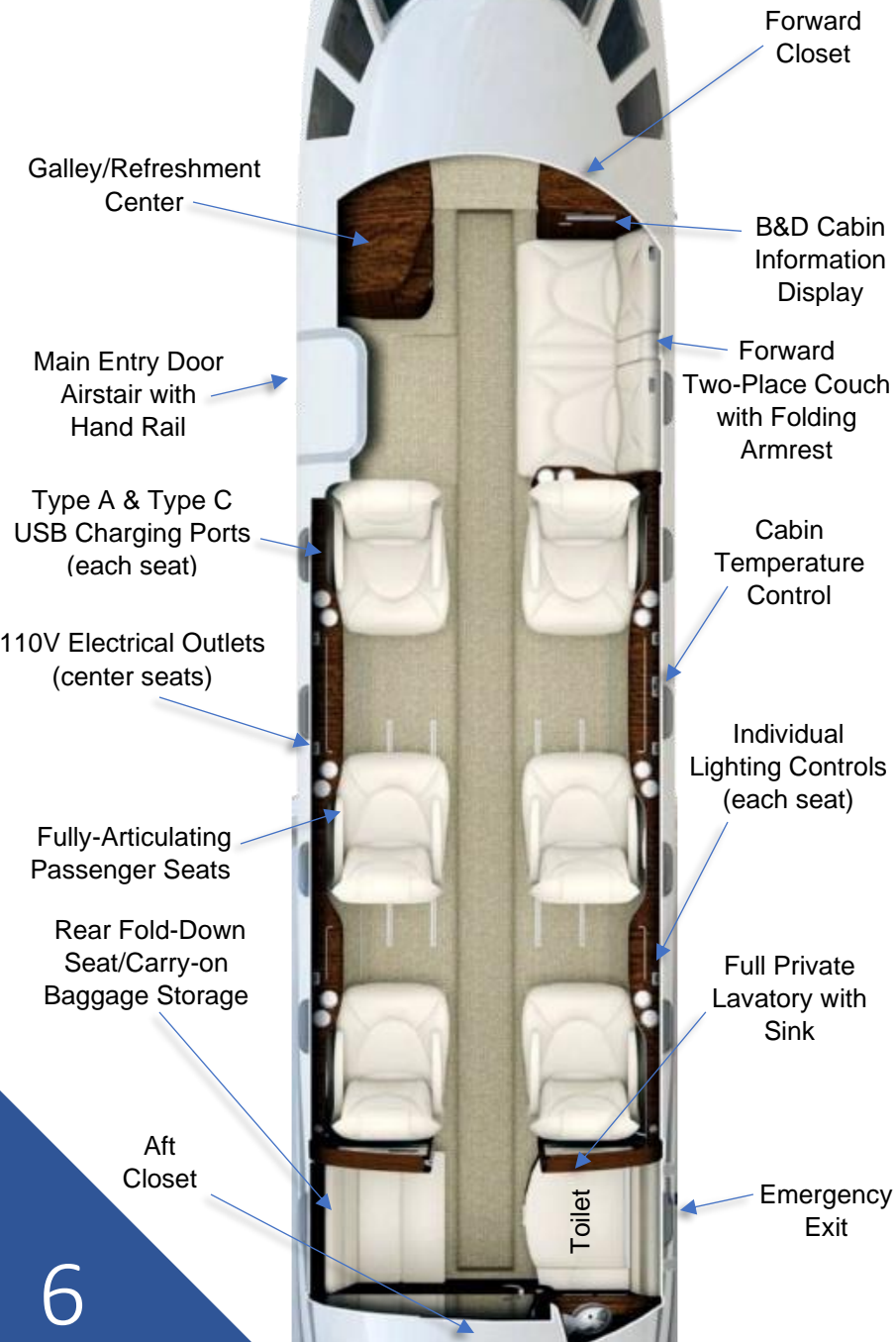

Cabin Information Display

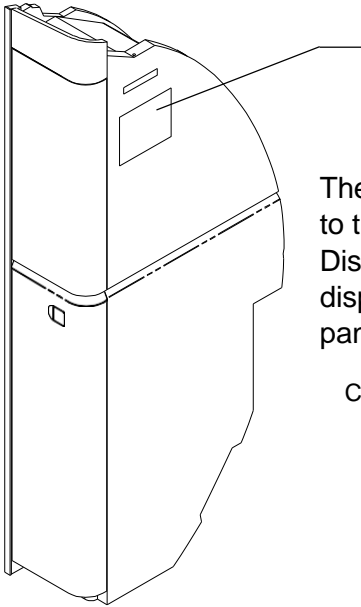

A Cabin Information Display is located on the aft side of the forward closet.

The Display provides in-flight information to the cabin passengers on an LED Display. The type of information being displayed is listed to the left of the LED panel.

Cabin Temp Selection Display

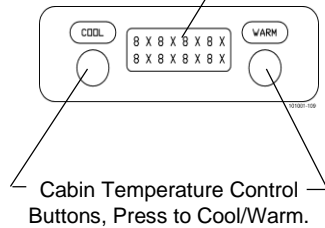

Passenger Comfort: Temperature Control

Aboard the Citation 560XL, Passengers have total control of the cabin heating and cooling.

Use the Cabin Temperature Control (shown above) located at the right-side forward-facing seat to control the cabin temperature for your comfort.

Cold air is available from the overhead vents, while warm air flows from the floor and sidewall ducts. In addition to selecting an overall cabin temperature, each individual can adjust their vents open or closed to attain their own perfectly comfortable temperature.

If for any reason you are unable to select a comfortable temperature, or would like the flight crew to adjust the cabin temperature from the cockpit, please don't hesitate to ask.

Your comfort is a priority to us.

Iridium GO! In-Flight Connectivity Guide

Step 1: Download the Iridium GO! App

Prior to the flight, search for “Iridium GO! App” on your smartphone’s app store. Install the app to your device.

Step 2: Connect to Air Direct WiFi

It is recommended that your device be placed in airplane mode prior to connecting to WiFi. This will conserve your device’s battery in flight. Enable WiFi on your iOS/Android device, and connect to the “**Air Direct WiFi**” network.

Step 3: Login to the App

Up to 5 devices may be wirelessly connected to the Iridium GO! network at any time, but only one user may make calls or access data at a time.

Launch the Iridium GO! App, and select ‘allow notifications’ if prompted by your device. Accept the End-User license agreement, and then enter the following login information:

Username: **guest**

Password: **1234**

If you do not automatically receive a login prompt, click the ‘Login’ button at the bottom of your app screen.

Note: It is recommended that you disable your Bluetooth option to avoid interference with the WiFi.

Note: On some Android devices, you may need to enable airplane mode, then connect to the Iridium GO! Wi-Fi.

Note: On some iOS devices, you may need select the WiFi network twice in order to connect.

Iridium GO! Functions

Status Bar



SOS: Activate Emergency SOS/GEOS - Call and Message



Contacts: Phone Contacts, Recent Contacts, Favorites



Help: First Time User Tips, Terms and Conditions, and About Iridium GO!



Advanced Settings: Firewall, Wi-Fi and User Management



General Settings for the Application and Iridium GO! Device



Call: Make and Receive Calls



Track: Tracking, GPS Location, Send Quick GPS



Message: Send and Receive Messages



Twitter: Send a Twitter Post



Login/Logout: Log In to/Log Out from Your Iridium GO! Device

Iridium GO! Quick Calling Guide

Make Calls using Iridium GO!

Select Call icon from the Iridium GO! App's home screen.

Ways to call:

- Enter the full dialing sequence:
00 or + [Country Code] [Phone Number]
- Use the Country Flag drop down menu
- Select from your existing contacts

Note: If you are dialing from existing Contacts, make sure to edit and insert the international access and country code (ex. +81) to complete calls on the Iridium network.

Note: Only one user at a time will be able to make a call on the Iridium Network.

Understanding the Iridium GO! App's "Status Bar":



Receive Calls through Iridium GO!

To receive calls on Iridium GO!, provide the caller with the aircraft's Iridium number. All calls to-and-from Iridium telephone systems are considered international calls.

The caller may direct dial or use two-stage dialing. Two-stage calls may provide you with more cost-effective calling.

In two-stage calls, the caller is charged by their long-distance provider for a call to Tempe, Arizona, USA for the call's duration. Direct dialing may not always be possible, as some long-distance providers may not recognize the Iridium Country Code (8816).



Direct Dialing to the Aircraft from ground phones

Dial IDD prefix (International Direct Dial prefix) of the country you are calling from (USA/Canada = 011) + Aircraft Iridium Telephone Number (8816.234.81391).

Receive Calls through Iridium GO! (Continued)



Making Two-Stage Calls to the Aircraft Within

USA/Canada: Dial 1.480.768.2500 & wait for prompt, then dial (8816.234.81391).



Outside USA/Canada: Dial IDD prefix of the country you are calling from, then dial 1 (USA Country Code) + 480.768.2500 & wait for prompt, then dial (8816.234.81391).

Send Messages through Iridium GO!



Select the Message icon from the Iridium GO! App's home screen; you'll now be able to view all conversations between the aircraft and the ground.

Click on compose icon option at the right corner of the screen.

Ways to send a message:

- Enter the full dialing sequence: 00 or + [Country Code] [Phone #]
- Select from your existing contacts in the space provided to "Enter Recipient"
- Use the plus "+" symbol to add from contacts

Note: If you are selecting from your existing Contacts, make sure to edit and insert the international access and country code (ex. +1).

Compose your text message in up to 1000 characters and enter in the space provided.

Click on the Send option on the bottom of the screen and your text message will be sent; you can select the conversation to view status of the message.

Note: SMS text messages will be delivered to all connected devices aboard the aircraft at the time.

Text conversations will be open to all users logged into the Iridium GO! 'guest' account during the flight.

Receive Messages through Iridium GO!

To receive messages provide your contact with the aircraft's Iridium GO! number, **8816.234.81391**. Free text messages up to 160 characters can be sent to your Iridium phone number from <https://messaging.iridium.com/>.

This is the most popular way to send SMS messages to an Iridium GO! number.

Alternatively, people can also text from their mobile phone directly but note that this will be considered as an international text and will be billed according to the caller at their long-distance messaging rate by their telephone service provider.

Note: Please check whether your mobile service provider allows international text messages to be delivered.

Note: SMS text messages will be delivered to all connected devices aboard the aircraft at the time.

Text conversations will be open to all users logged into the Iridium GO! 'quest' account during the flight.



Cabin Switch Panels

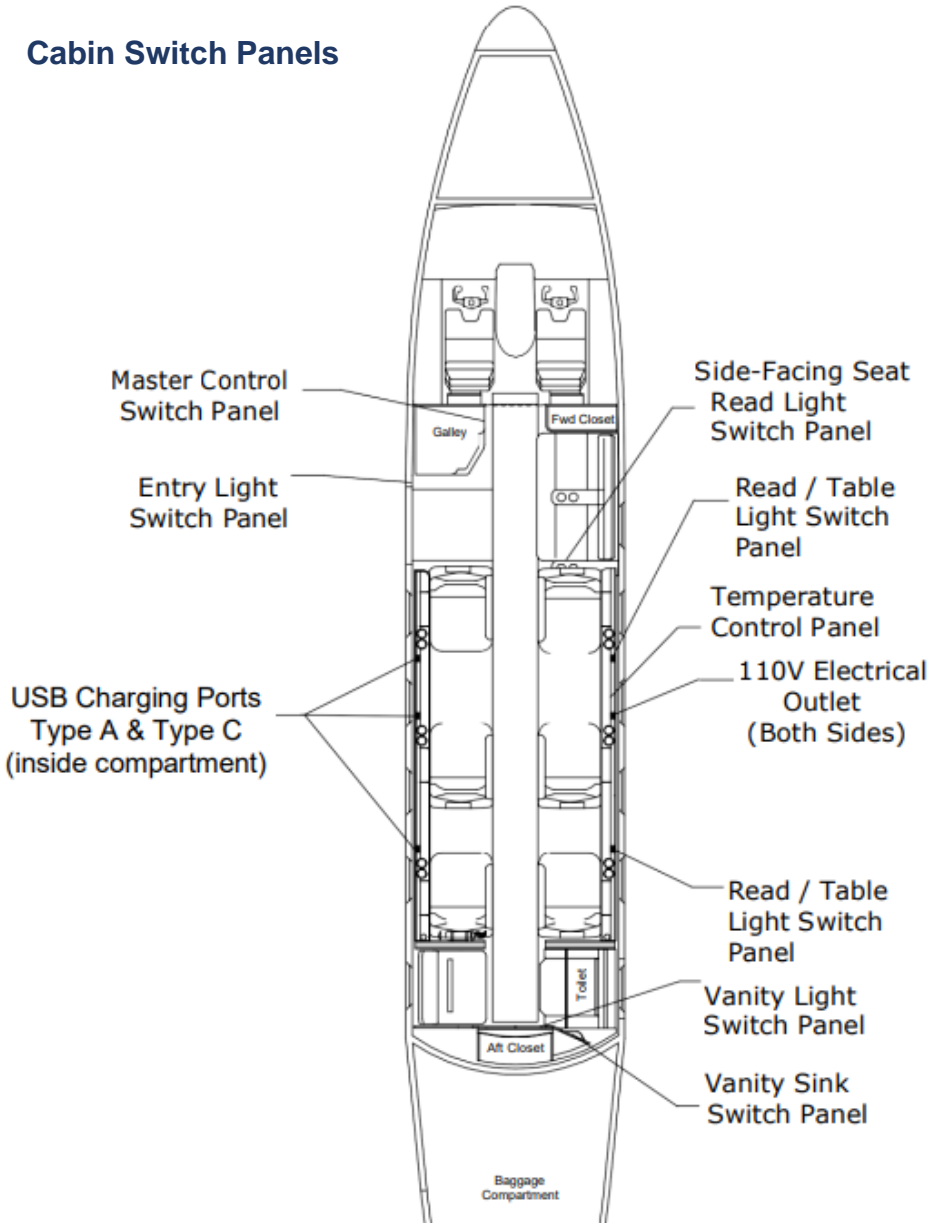

Master Control Switch Panel

(Located in Galley Header)

Press to Turn Lighting On/Off
(Light Designates On)

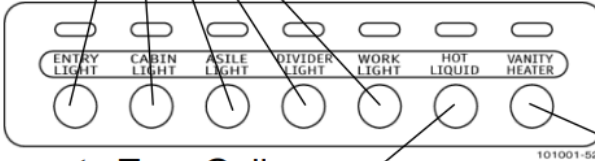

Press to Turn Galley
Hot Liquid Heater
On/Off
(Light Designates On)

Press to Turn Vanity
Hot Water Tank Heater
On/Off
(Light Designates On)

Read / Table Light Switch Panel

Press to Turn Light On,
Press Again for Off

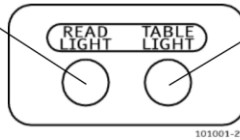

Press to Turn Table
Light On, Press
Again for Off

Entry Light Switch Panel

Press to Turn Cabin
Lights On, Press
Again for Off

Press to Turn Entry
Lights On, Press
Again for Off



Door Lock Indicators
(Lights Extinguished
Designates Locked)

Temperature Control Switch Panel

Cabin Temp Selection Display

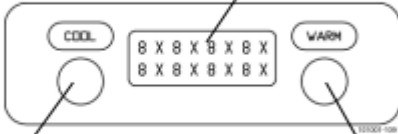

Cabin Temperature Control Buttons, Press to Cool/Warm.

Vanity Light Switch Panel

Press to Turn Cabin Lights On,
Press Again for Off
(Light Designates on)

Press Once to Turn On
Vanity Water Tank Heater
(Light Designates on)



Press to Turn Seat
Light On,
Press Again for Off
(Light Designates on)

Vanity Sink Switch Panel

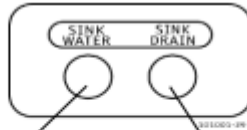

Sink Water Switch.
Press for Water

Sink Drain Switch.
Press to Drain

Furniture Location & Operation

Seat Adjustment

Passenger seats have forward, aft and lateral adjustment with seat back recline.

By pulling the armrest seat adjustment lever up, it is possible to adjust the Seat position forward, aft, out from the wall or swivel to face any direction.

Push Lever down to recline the seat back.

To raise the armrest, pull up fully and armrest will lock in full- up position.

To lower armrest, lift up slightly to unlock and lower armrest.

The headrest can be adjusted up and down to desired position. A slipcover headrest pillow is installed for additional comfort.

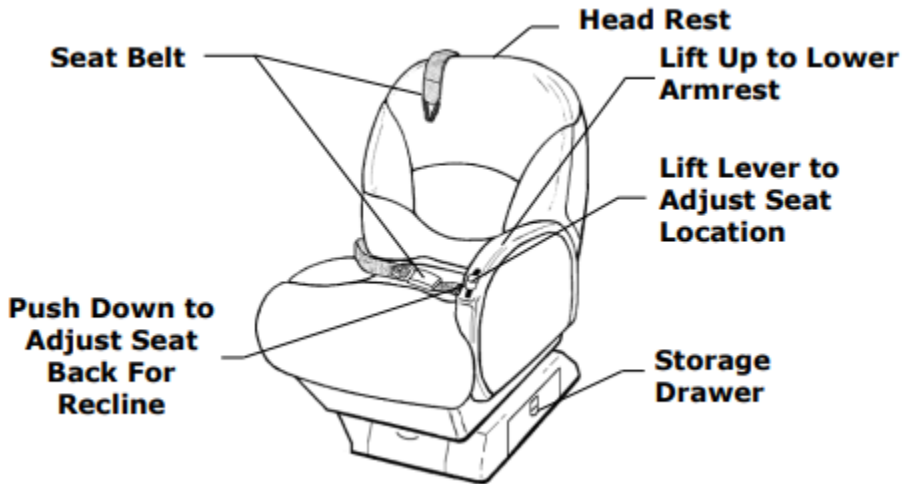

Note: Return seat to its normal position during takeoffs and landings. See Passenger Briefing Card for complete instructions.

Table Operation

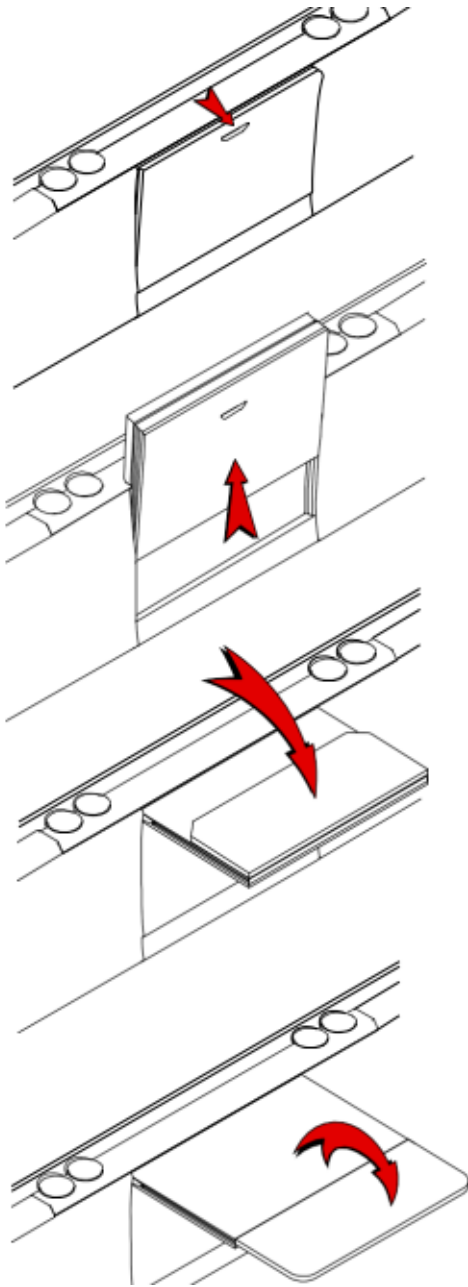

1. Open table door.
2. Lift table up.
3. Rotate table down until it is at rest in down position.
4. Unfold table leaf.
5. Reverse steps 1 through 4 to stow table.

Note: Return table to its stowed position during takeoffs and landings. See Passenger Briefing Card for complete instructions.

Galley

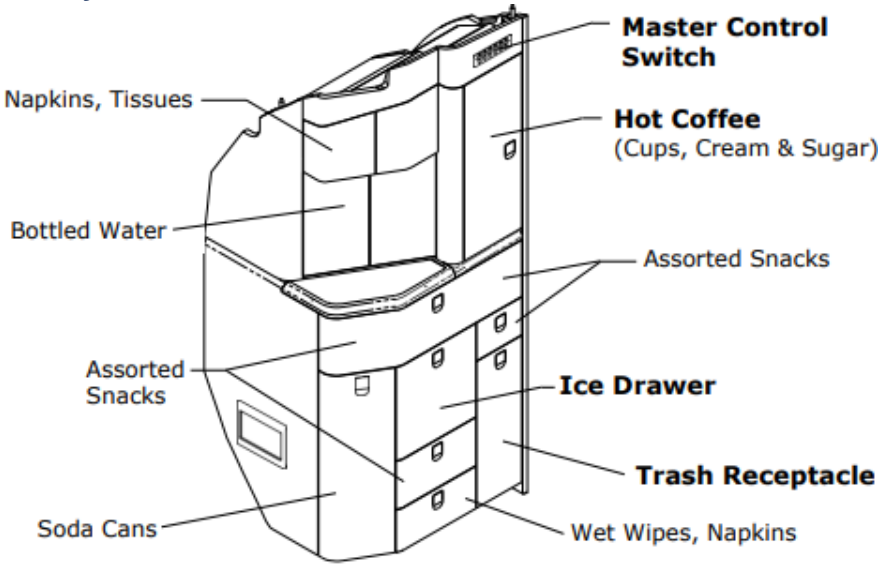

Hot Liquid Container Switch Panel

The master cabin control switch panel located in the galley header controls the hot liquid container.

Pressing the switch once will turn the hot liquid container heater on, pressing again will turn heater off.

Press to turn
Galley Hot Liquid
Container Heater
On and Off (Light
Designates On)

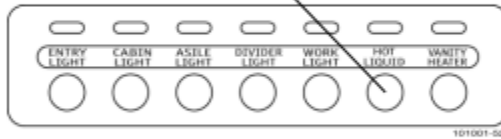

Master Cabin Control Switch Panel
(Located in Galley Header)

Manual Window Shade Operation

Cabin Window Shades open and close by sliding the shade handle from right to left.



Lavatory

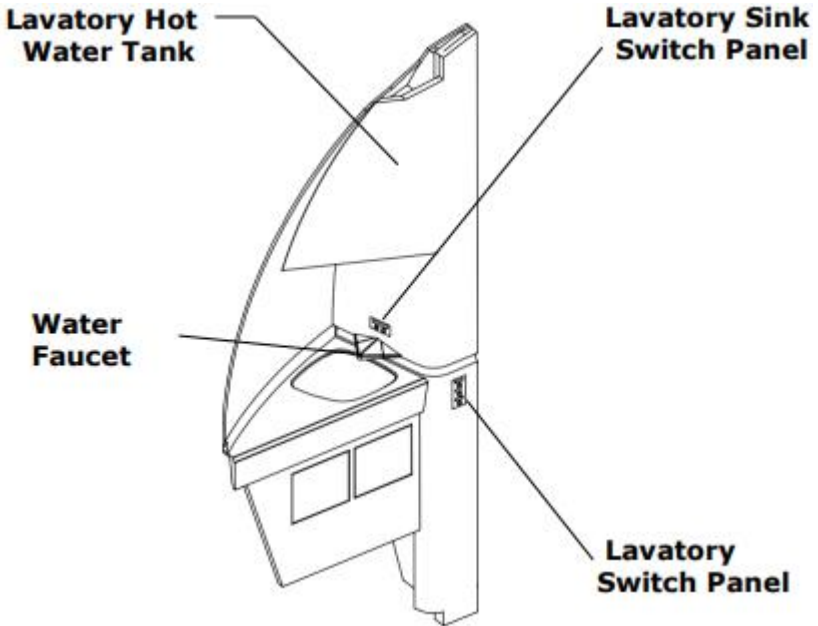

Lavatory Water Heater Operation

The lavatory switch panel controls the heater for the water tank. Press the WATER HEATER button to turn water heater on, light indicates heater is on. The Water tank may take several minutes to warm up. Pressing the WATER HEATER switch again will turn the water heater off.

Press Once to Turn On Lavatory Water Tank Heater, Press again for Heater Off (Light Designates on)

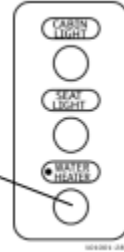

Toilet

Press to Flush Toilet

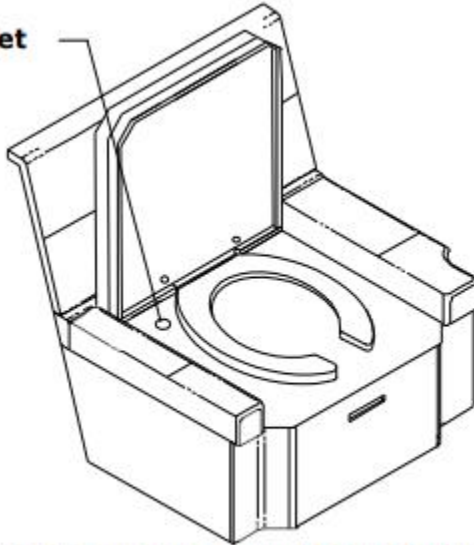

(Toilet Paper is located in a dispenser next to the toilet.)

Emergency Equipment

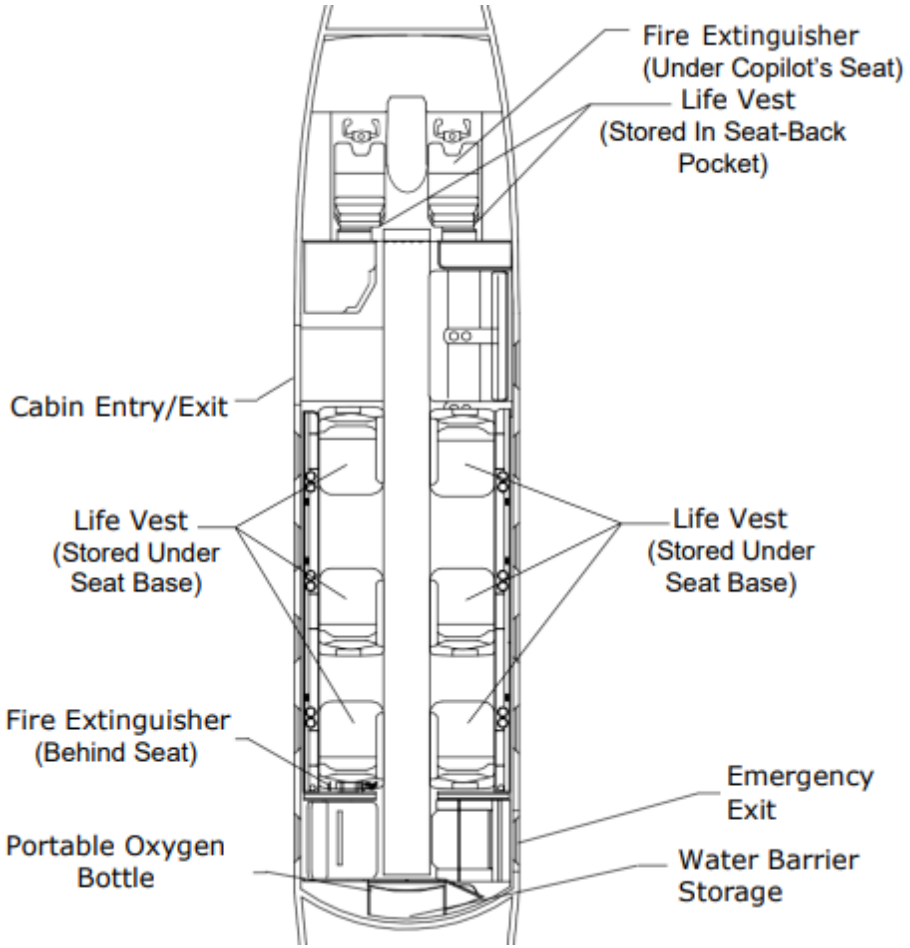

Brace Positions

Assume brace positions as shown below.

FORWARD

REAR



Side-Facing Seat



Rear-Facing Seat



Forward-Facing Seat

Emergency Exits

The airplane has two exits with emergency exit releases and signs.

To Open Cabin Entry Door:



1. Push button pull handle out from stow position and rotate counter clockwise to the open position.



2. Push door to open. If door should not open, pull pre-catch lever on forward side of door. Ensure handle returns to stow position.



3. While pushing door out and down, grasp lever handle and push down to the floor.

4. Exit airplane and move away from airplane.



To Open Emergency Exit Door:



1. Remove plastic cover and rotate handle clockwise.



2. Pull door in.



Discard door through opening away from walkway.



4. Exit airplane onto wing walkway and move forward and away from airplane.

Fire Extinguishers

Two portable hand-held fire extinguishers are installed in the airplane. One extinguisher is located in the cockpit under the copilot's seat. The other extinguisher is located behind the left-hand rear seat and is accessible to all passengers.

The portable fire extinguishers are pressurized bottles containing a Halon Type 1211 extinguishing agent. The bottles have an actuating valve operated by hand and the extinguishers are rated for Class B and C fires.

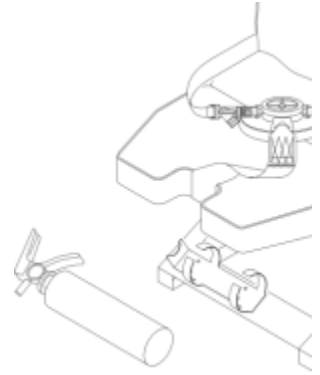

Copilot Seat

To operate fire extinguisher:

1. Hold upright and pull out the locking pin on the operating lever.
2. Stand back six (6) feet.
3. Aim at the base of the fire, not at the smoke or flame, and squeeze lever.
4. Sweep fire extinguisher side to side.

First Aid Kit

A First Aid Kit is provided for minor emergencies. The First Aid Kit is stored behind the right-hand rear seat in the cabin.

Consult with aircraft crew in the event of any injury or emergency requiring first aid.

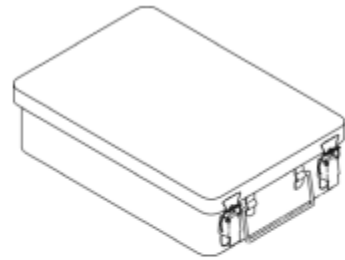

Flashlights

Flashlights are included aboard for use in an emergency.

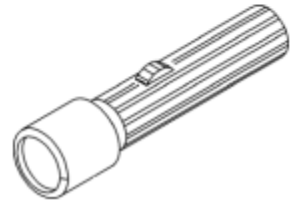

Note: Flashlights are stowed in mounts located on the front of the forward bulkhead, behind the cockpit.

Life Vests

Life vests are located in the base of each passenger seat for use in the event of an over-water emergency landing. (Refer to the life vest location placard for your seat.) A life vest is also located in the pocket on the back of the pilot and copilot seats. Instructions for use of the life vests are provided on a placard on each vest and on the passenger-briefing card located at each seat.

Caution: Put life vest on prior to ditching, but do not inflate until outside of airplane.

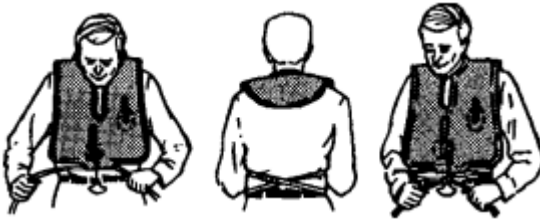

1. Slip vest over head and criss-cross the nylon straps behind you and around your body, then tie the straps in front.

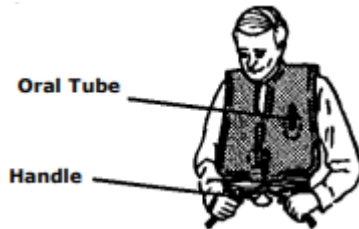

2. Jerk handle to inflate vest. (An oral tube with a one-way valve is also provided to inflate vest.)

Overhead Oxygen Masks

Should the airplane lose pressurization, an overhead oxygen mask will automatically drop over each passenger seat.

1. Extinguish any smoking materials.
2. Pull down on mask until lanyard cord falls free.
3. Place mask over nose and mouth and breathe normally.
4. Place the strap over your head to secure.
5. Help children or other passengers with their masks only after your own mask is in place.

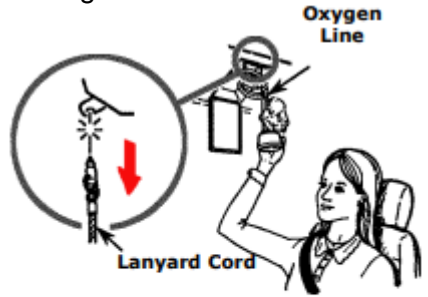

Seat Belts

It is recommended that seat belts remain fastened during flight. For comfort, the optional shoulder harness may be detached during flight.

Note: Seatbelts and shoulder harness must be fastened during takeoff and landing. See Passenger Briefing Card for complete instructions.

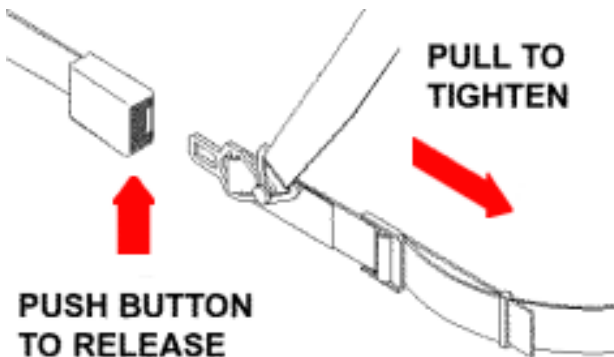

Portable Oxygen Bottle

A portable oxygen bottle is located in the aft closet for use in the event of a medical emergency.



1. Extinguish any smoking materials or sources of flame.
2. Plug oxygen mask (stored with bottle in aft closet) into portable oxygen bottle.
3. Turn valve counter clockwise to turn on oxygen bottle.
4. Place mask over nose and mouth and breathe normally.
5. Place the strap over your head to secure.